

Veejay Automatic Cone Winder Installation diagrams and Dimensions For R.H. Machine

All Dimensions are in mm.

Heights refer to machines with levelling bolts adjusted to 80mm from the ground.

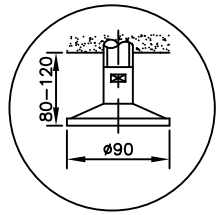
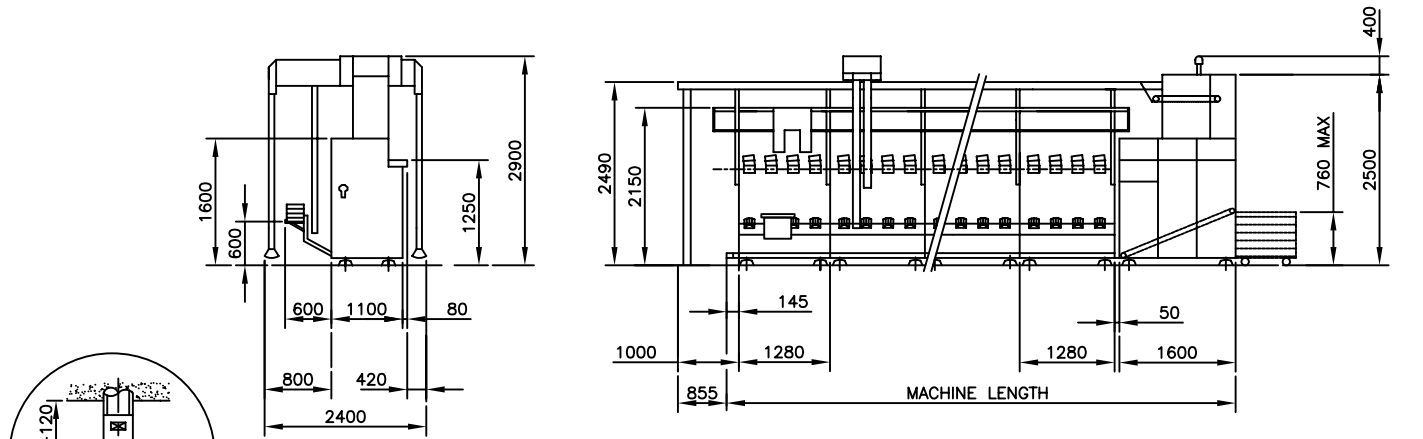

Base

Number of winding heads	Machine Length in mm.
12	5635
16	6915
20	8195
24	9475
28	10755
32	12035
36	13315
40	14595
44	15875
48	17155
52	18435
56	19715
60	20995
64	22275

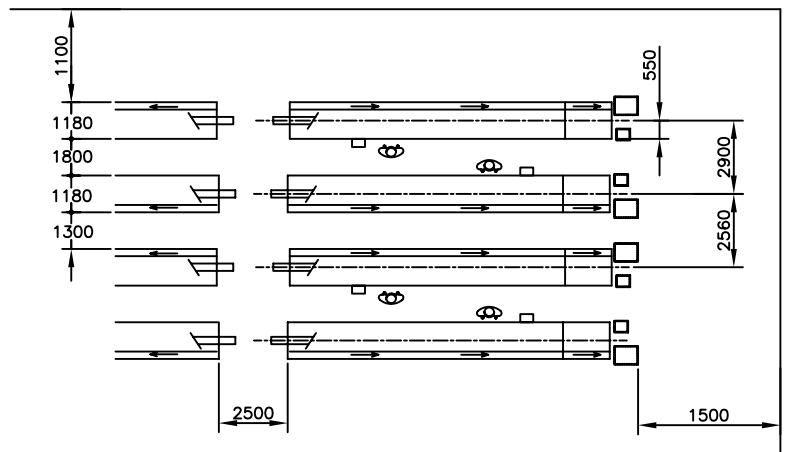
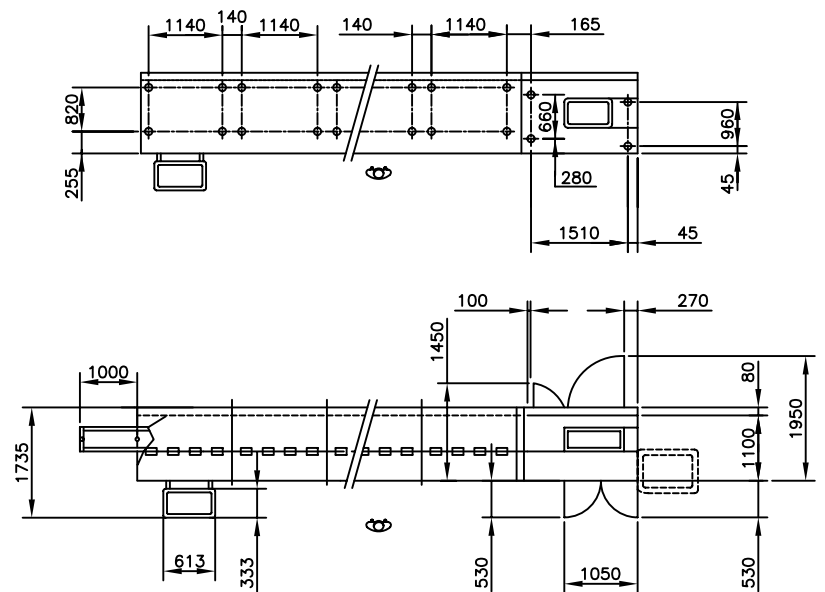

Machine installation minimum dimensions in mm.

Veejay Automatic Cone Winder Installation diagrams and Dimensions For L.H. Machine

All Dimensions are in mm.

Heights refer to machines with levelling bolts adjusted to 80mm from the ground.

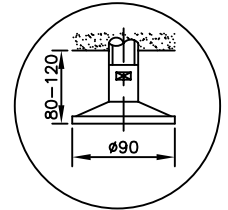
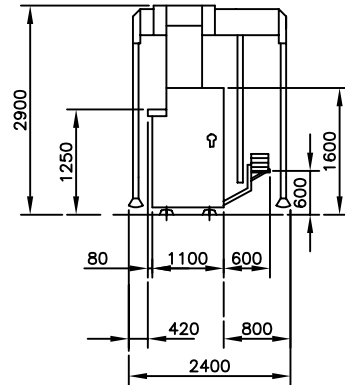
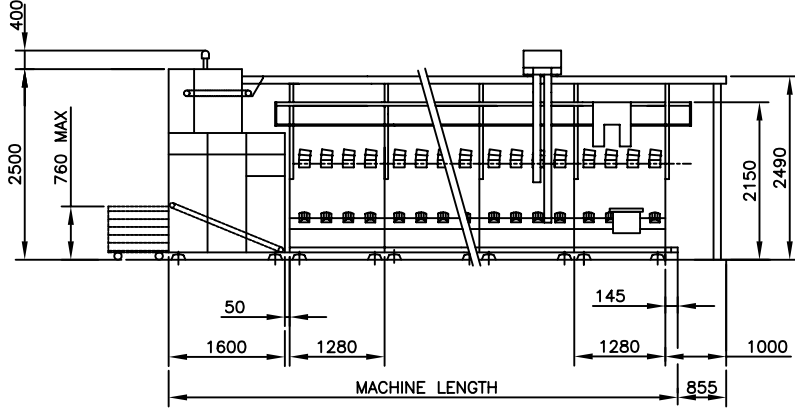

Base

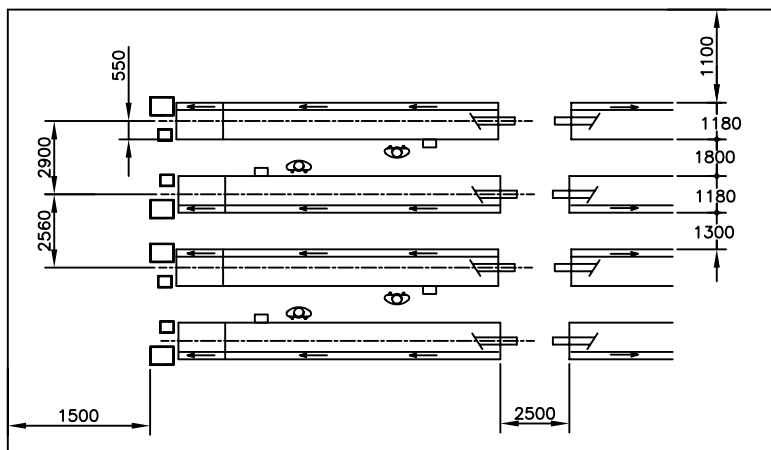
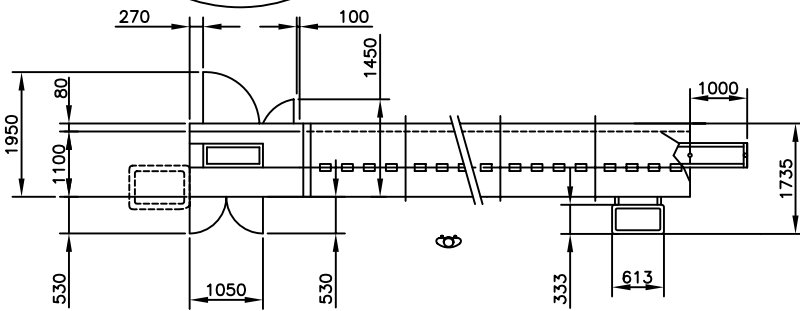
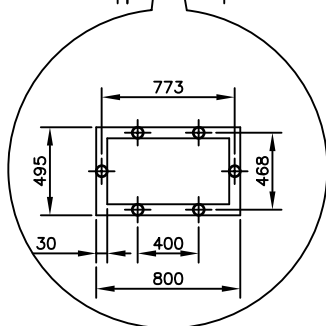
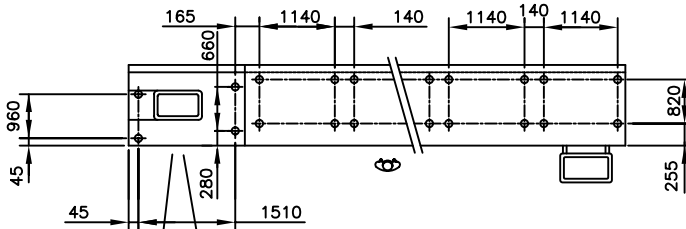

Machine installation minimum dimensions in mm.

Number of winding heads	Machine Length in mm.
12	5635
16	6915
20	8195
24	9475
28	10755
32	12035
36	13315
40	14595
44	15875
48	17155
52	18435
56	19715
60	20995
64	22275